



Springs Window Fashions LP

Window Treatment Vertical Blinds

Graber® G-85 Dura-Vue™ Headrail



PART 1—GENERAL

1.01 DESCRIPTION

A. Related Requirements

1. The Conditions of the Contract (General and Supplementary, and other Conditions), and Division 1 General Requirements (if any) are part of this section. (Delete or retain as appropriate.)

1.02 QUALITY ASSURANCE

A. Job Mock-Up: (Describe)

1.03 SUBMITTALS

- Manufacturer's Product Data:** Submit manufacturer's descriptive product data and installation instructions for each type of blind specified.
- Shop Drawings:** Submit shop drawings indicating the following:
 1. Field-measured dimensions of openings scheduled to receive blinds.
 2. Illustrations of special accessory components not included in manufacturer's product data.
 3. Details of head and sill conditions, corner conditions, and conditions between adjacent blind units.
- Color Sample:** Submit two 6" samples of louver material indicating full color range and variation.
- Product Sample:** Submit one 16" wide fully functional vertical headrail.
- Maintenance Material (Extra Stock):** (Describe)

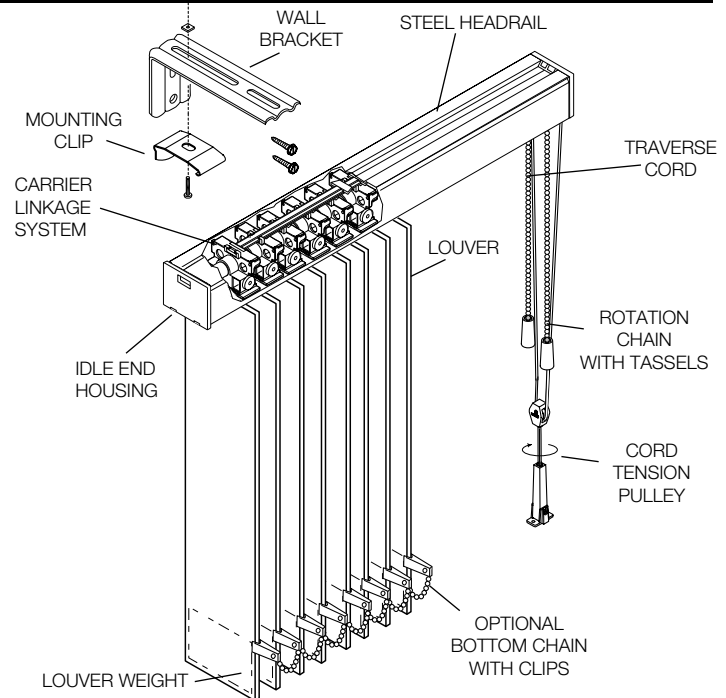

G-85 Dura-Vue Vertical Blind

PART 2—PRODUCTS

2.01 VERTICAL BLINDS

A. Manufacturer and Product:

- Manufacturer:** Springs Window Fashions LP
 - Product:** Graber G-85 Dura-Vue Vertical Blind Headrail System.
 - Options:** (Describe)
 - Color(s):** Selected from Graber Vertical Sample Selector.

B. Product Description:

- G-85 Dura-Vue Headrail Format:**
 - Track shall be roll formed 22-gauge steel with baked on Ivory gloss enamel. The headrail shall measure 1½" wide and 1¼" high.
 - Carrier body shall be molded nylon with a detachable louver stem molded in clear non-yellowing acetal. Carrier shall traverse on self-lubricated wheels to reduce draw force, and the louver stem shall be replaceable without demounting the headrail. Carriers are located in the center channel making headrail reversible.
 - Rotation of louvers shall be provided by pulling a #6 nickel-plated bead chain finished with tassels which rotates a gear assembly in the control housing. This drives an extruded (.300 dia.) aluminum pinion rod passing through all carriers and transmits rotation to each louver stem through a molded rack and pinion gear system. The drive system shall rotate all louvers simultaneously a full 180 degrees and hold them in a fixed position until reset.
 - Spacing of louvers shall be achieved with a nylon spacer arm integral with carrier body. Visually uniform louver spacing is provided when the blind is fully drawn. In the closed position, louver overlap shall be no less than 3/8".
 - Traversing shall be by means of a pulley system and a #3 (.094") traverse cord attached to the lead carrier. The self-lubricating cord pulley wheels of the drive-end shall rotate freely on their axles to allow for smooth traversing with a minimum draw force. The traverse cord shall have a minimum tensile strength of 125 pounds and a maximum stretch while in use not to exceed 1%. The cord shall be held down by a cord tension pulley that is attached to the floor, sill or jamb. The center spaced louvers allow one way traverse installations to draw from right or left.

f. Traversing:

Optional headrail may be supplied without traverse cord for non-traversing blind.

- Optional One Touch® Control Wand:** This optional control replaces standard cord and chain controls. Pultruded fiberglass wand rotates and traverses louvers. Wand control incorporates clutch to eliminate damage by over rotation of wand. Size limitation with One Touch control is 70 square feet. Maximum width is 156" with a 64½" drop. Maximum drop is 114" with an 88" width. Maximum drop of 114" includes sill height in overall measurements. Split draw not available with One Touch Control option. Only 3½" louver widths available on One Touch Control.

2. Louvers

- Louvers shall be selected from the Graber Vertical Louver Sample Selector. All vertical louvers shall be manufactured to exacting standards to resist fading, twisting and brittleness. Fabric louvers shall contain a bottom weight pocket sewn at the bottom with clear, poly thread. Each pocket shall contain one weight. Standard specification shall be no bottom chain for PVC, aluminum and fabric louvers. Optional specification shall be single bottom chain. Note: Bottom chain not available with fabrics inserted in groove.
- Installation Brackets** shall be provided to support the weight of the blind plus forces applied to operate the blind. Include hardware necessary for secure attachment of brackets to adjoining construction and headrail. Brackets shall be designed to facilitate installation and removal of headrail.
- General:** The blind shall be free of sharp edges, burrs or other defects which might be harmful. When other materials result in improved specifications, they may be adopted.
- Size Limitations for Cord Draw/Chain Rotation Controlled Blinds with 3½" Louvers:**
 - Maximum width:** 191"
 - Maximum drop:** 144"
- Size Limitations with Channel Panel Louvers:**
 - Maximum drop:** 120"
- Size Limitations with 2" PVC Louvers:**
 - Maximum width:** 157½"
- Size Limitations and Louver Sizes for One Touch Control Option:** See point "g" above

Window Treatment Graber® G-85 Dura-Vue™ Vertical Headrail

2.02 FABRICATION

- A. Prior to fabrication, verify actual opening dimensions by on-site measurement. Calculate blind dimensions to fit within specified tolerances.
- B. Fabricate blinds to fill openings from head to sill and jamb to jamb. Locate blind divisions at mullions.
- C. Fabricate blinds to fill all exterior window openings except at doors, door sidelights and transoms unless noted.

PART 3—EXECUTION

3.01 INSPECTION: Verify that the work area in which the blinds will be installed is free of conditions that interfere with blind installations and operations. Begin blind installation only when unsatisfactory conditions have been corrected.

3.02 INSTALLATION

- A. Install blinds in accordance with manufacturer's installation procedure except as otherwise specified herein.
 - B. Install all brackets provided to prevent deflection in headrail.
 - C. Install blinds with adequate clearance to permit smooth operation of blinds and any sash operators.
 - D. Demonstrate blinds to be in smooth, uniform working order.
 - E. Store installed blinds in fully stacked position to avoid damage and accumulation of dust and dirt until such time that these conditions are eliminated.
-

3.03 CLEANING

If solid vinyl or aluminum louvers become soiled, wipe or sponge using a mild detergent and warm water solution. With fabric louvers, dust or vacuum with an upholstery attachment; for soil removal, sponge using a mild detergent and warm water solution (or a dry fabric cleaner) and blot dry. Do not immerse in water or dry clean.

3.04 VERTICAL BLIND SCHEDULE

Provide blinds at the following locations (Listing of blind locations, different options, types, accessories and colors).

